

## CLAMP CONNECTION DIAPHRAGM SEAL

Diaphragm seals are designed to isolate the sensing element of the pressure gauges and pressure switches from process fluids that may be corrosive, viscous, sedimentous and/or with a high temperature. The diaphragm is welded to the upper body, to ensure separation of the filling fluid from the process medium. Faced diaphragm position enables deep cleaning of the surface while the quick-connection Tri-clamp enables a frequent removal from the process during sterilization and cleaning operations, a common requirement in the food processing industry.

### Constructive and functional characteristics:

**Pressure range:** see Scales table.

**Working temperature:** -20°C..+120°C.

**Accuracy (20°C):** (add to instrument accuracy)  $\pm 0,5\%$  (only for direct assembly).

**Instrument connection:** AISI 316 st.st. 1/4" BSP F or 1/2" BSP F with ball and set screw threaded M5 for filling.

**Diaphragm:** AISI 316 L st. st., welded.

**Filling liquid:** oil for food industry.

**Process connection:** AISI 316 st. st. 1", 1½", 2", 2½", 3" Clamp.

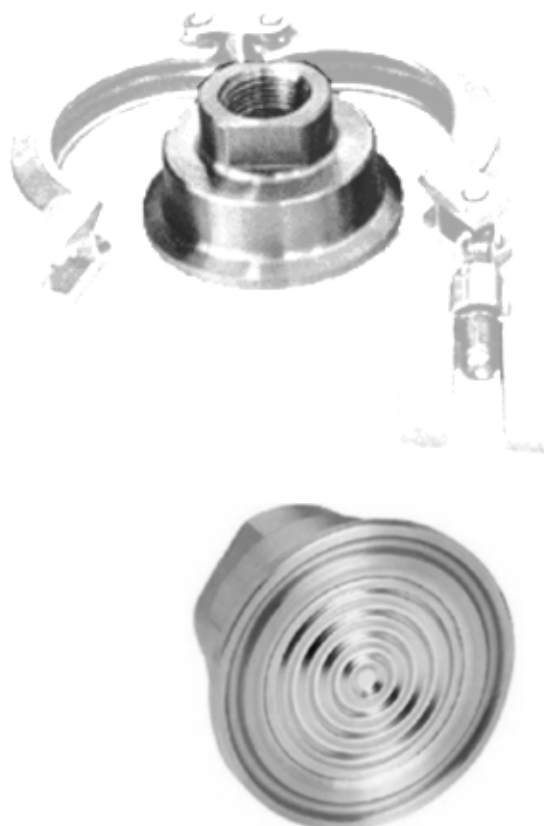

## SCALES

DN Clamp	Pressure gauge		
	DN63	DN100	DN150
1" Clamp	0..6÷0..40 bar	--	--
1"1/2 Clamp	0..2,5÷0..40 bar	0..2,5÷0..40 bar	0..4÷0..40 bar
2" Clamp	--	0..1÷0..40 bar	0..2,5÷0..40 bar
2"1/2 Clamp	--	0..1÷0..25 bar	0..1,6÷0..25 bar
3" Clamp	--	0..1÷0..25 bar	0..1÷0..25 bar

This publication does not try to establish the bases of a contract and the company keeps the right to modify without previous notice the design and the specifications of the instruments, in accordance with his politics of continued development.

**MEI Manometría e Instrumentación, s.l.**

**Pol. Ind. "El Pla" C/ Comerç, 2-22 nave 13 E-08980 Sant Feliu de Llobregat Barcelona Spain**  
**Tf. +34 934 403 939 Fax. +34 934 483 986 www.mei.es e-mail: info@mei.es**

**DIMMENSIONS IN mm**

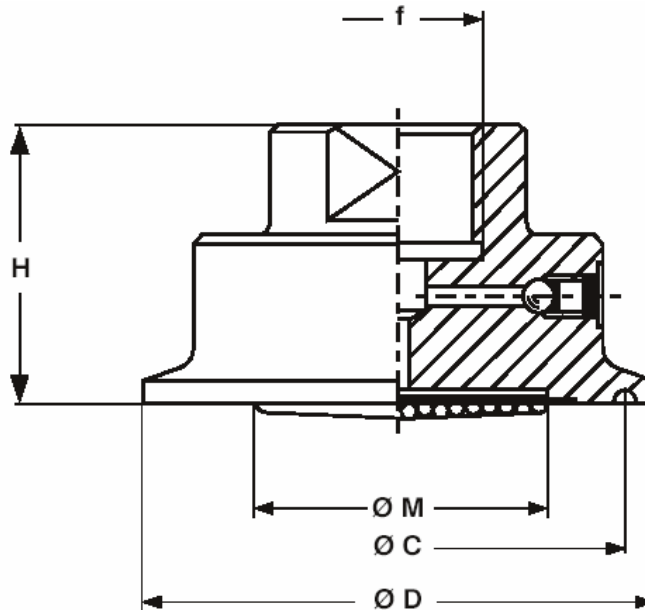

DN Clamp	C	H	D	f	M
1"	43,5	30	50,5	¼" BSP	20
1"1/2	43,5	35	50,5	¼" ó ½" BSP	30
2"	56,5	35	64	½" BSP	40
2"1/2	70,5	35	77,5	½" BSP	50
3"	83,5	35	91	½" BSP	65

This publication does not try to establish the bases of a contract and the company keeps the right to modify without previous notice the design and the specifications of the instruments, in accordance with his politics of continued development.

**MEI Manometría e Instrumentación, s.l.**

**Pol. Ind. "El Pla" C/ Comerç, 2-22 nave 13 E-08980 Sant Feliu de Llobregat Barcelona Spain**  
**Tf. +34 934 403 939 Fax. +34 934 483 986 www.mei.es e-mail: info@mei.es**