

CAPSULE PRESSURE GAUGES FOR LOW PRESSURES DN 100

They are use for measure very low pressures in gases, in pressure and in vacuum, mainly in gases, between 600..0/0..600 mbar ranges.

Constructive and functional characteristics

Precision: Class 1,6 according to EN 837-3.

Ranges: -600..0 a 0..600 mbar or any other equivalent unit of pressure or vacuum, standard ranges according to EN 837-3. Double scale in mbar and mmH₂O

Ambient temperature: -20...+65 ° C.

Process fluid temperature: max. +65° C.

Temperature error:

Additional error when the temperature of the sensitive element turns aside of 20°C: ±0,5% of the value E.S. every 10°C.

Working Pressure:

Max. static pressure. 75% E.S.
Fluctuating pressure: 2/3 E.S.

Temporary overpressure:

+25% Maximum range value during a short time.

Outdoor grade of protection:

IP31 (indoor use).

Process connection: Lower connection 1/2" BSP

Process connection racord: In brass.

Capsule: phosphorous bronze.

Mechanism: in brass.

Box: In Stainless steel, bayonet bezel.

Window: Glass.

Pointer: in painted black aluminium.

Zero adjustment: by adjustment screw in the frontal side.

Options: All stainless steel construction.



This publication does not try to establish the bases of a contract and the company keeps the right to modify without previous notice the design and the specifications of the instruments, in accordance with his politics of continued development.

DIMENSIONS

inches
(mm)

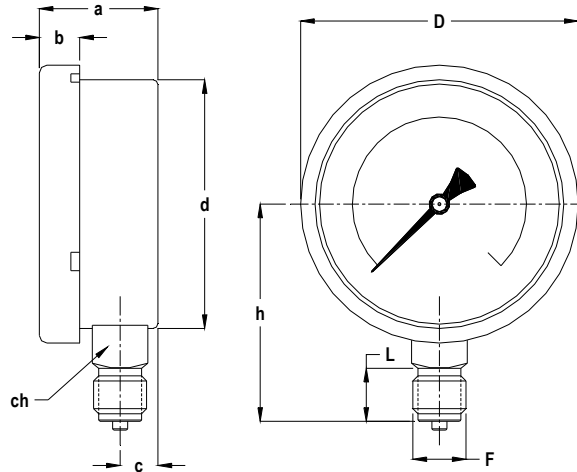

TYPE 1

Local assembly
Lower connection

DN	TYPE	a	b	c	ch	d	D	F	h	L
3.94" (100)	1	1.85" (47)	0.59" (15)	0.59" (15)	22x4	3.90" (99)	4.33" (110)	3.35" ½" BSP	3.35" (85)	0.79" (20)

This publication does not try to establish the bases of a contract and the company keeps the right to modify without previous notice the design and the specifications of the instruments, in accordance with his politics of continued development.

MEI Manometría e Instrumentación, s.l.

Pol. Ind. "El Pla" C/ Comerç, 2-22 nave 13 E-08980 Sant Feliu de Llobregat Barcelona Spain
Tf. +34 934 403 939 Fax. +34 934 483 986 www.mei.es e-mail: info@mei.es